

REVISIONS				
SYM	ZONE	ECN, ERN NO.	DATE	APPRD.
C		ADD DIMENSION FOR CONTACT	NOV 14/06	L.CHAN
D		PROPOSAL	OCT 24,08	L.CHAN

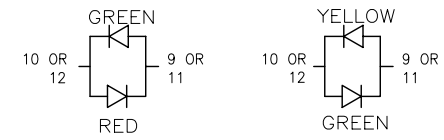

BI-COLOUR LED DETAIL
 (RED/YELLOW AND GREEN/ORANGE LED'S ARE ALSO AVAILABLE)

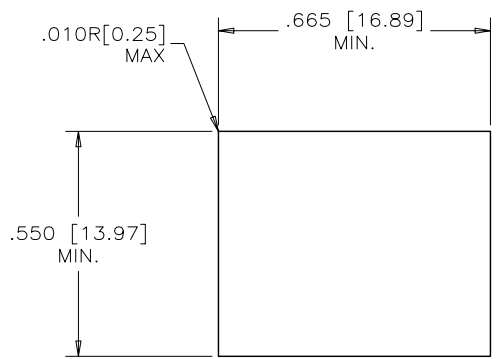
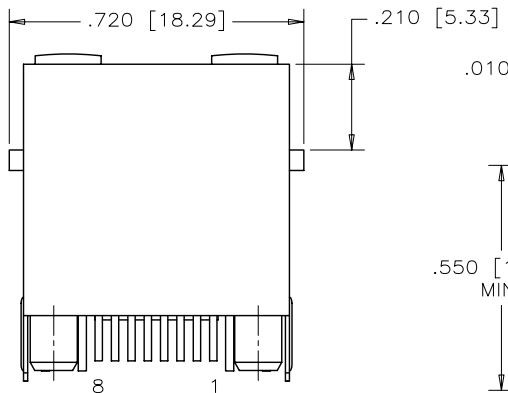

RECOMMENDED PANEL CUTOUT

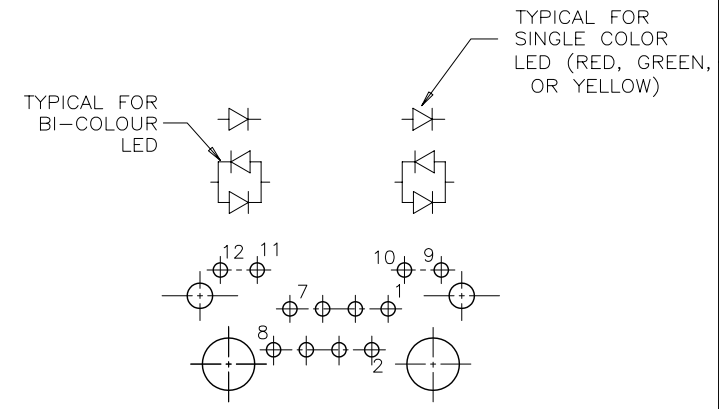

LED SCHEMATIC

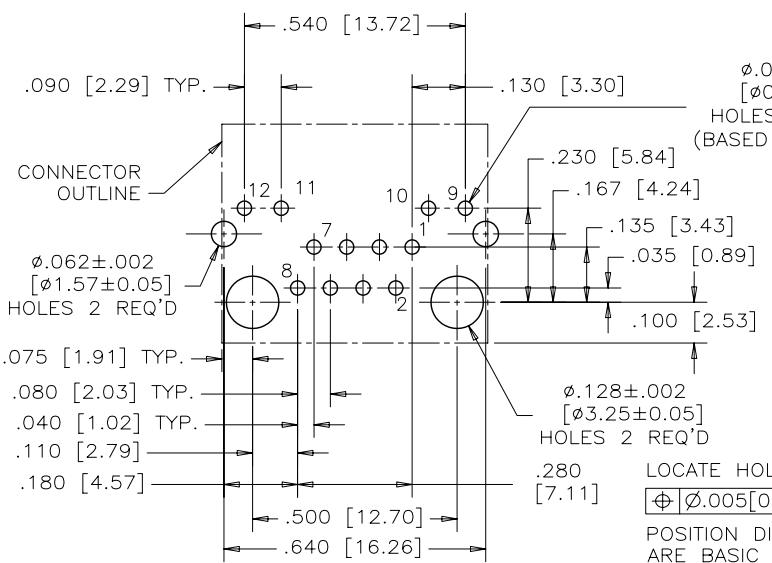

RECOMMENDED P.C.B. LAYOUT
 (COMPONENT SIDE OF BOARD)

LOCATE HOLES
 [Ø.005 [0.13]]
 POSITION DIMENSIONS ARE BASIC



MATERIALS:

- PLASTIC HOUSING: HIGH TEMPERATURE THERMOPLASTIC
 FLAMMABILITY RATING UL 94V-0
- CONTACTS: PHOSPHOR BRONZE
 (FLAT) PLATING: 30 µ" [0.76 MICRONS]
 MIN. GOLD ON MATING SURFACES.
 50 µ" [1.27 MICRONS]
 MIN. NICKEL UNDERPLATE
 100 µ" [2.54 MICRONS]
 MIN. MATTE TIN ON CONTACT TAILS.
- SHIELD: COPPER ALLOY
 PLATING: NICKEL WITH PURE-TIN DIPPED PCB TAILS.
- RECOMMENDED SOLDERING TEMPERATURE:
 WAVE SOLDERING TEMPERATURE AT 260°C MAXIMUM
 FOR 5 SEC MAXIMUM.

AMPHENOL PART NUMBER: RJHSE-338X

REFER TO LED OPTIONS DRAWING FOR ORDERING CODES

THIS DOCUMENT CONTAINS PROPRIETARY INFORMATION AND SUCH INFORMATION MAY NOT BE DISCLOSED TO OTHERS FOR ANY PURPOSE OR USED FOR MANUFACTURING PURPOSES WITHOUT WRITTEN PERMISSION FROM AMPHENOL CANADA CORP.

DRAWN PAULW	DATE JUL04/06	Amphenol Canada Corp.	
DESIGNED			
CHECKED CHIGOW	JUL04/06	TITLE	
I. E. APPRD.		SINGLE-PORT HIGH SPEED MODULAR JACK, 8 POSITIONS, 8 FLAT CONTACTS, WITH LED'S AND SHIELD - RoHS COMPLIANT	
Q. A. APPRD.		REF.	
DWG. APPRD.		DWG	DRAWING NO.
ENG. REL. NO.			P-RJHSE-338X
REF.			REV. D
DIMENSIONS ARE IN INCHES [mm]	CODE ID. NO. 03554	SCALE	WT. ----- SURF. ----- SHEET 1 OF 1

REVISIONS				
SYM	ZONE	ECN, ERN NO.	DATE	APPRD.
A		PROPOSAL	SEP21/04	

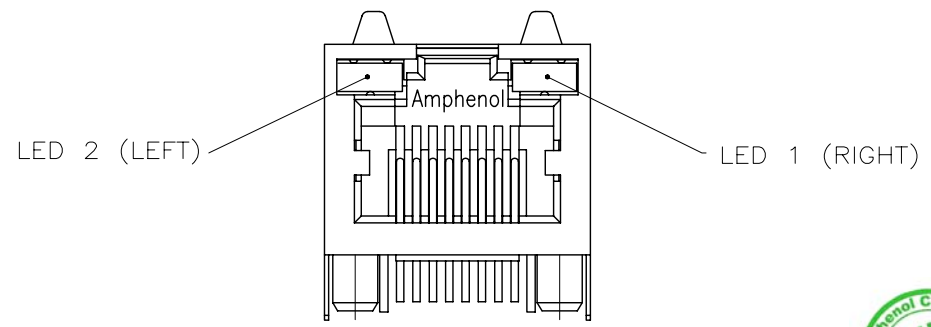

TYPICAL FOR SINGLE & MULTI-PORT



LED SPECIFICATIONS:
 FORWARD VOLTAGE: 2.1 VOLTS TYP.
 REVERSE VOLTAGE: 5.0 VOLTS MIN.
 LUMINOUS INTENSITY: 0.5 mCd MIN.
 (AT If=2mA)
 STORAGE TEMPERATURE: -20° TO 85° C
 LEAD SOLDERING TEMPERATURE: 260° C
 (5 SEC, 1/16" FROM CASE)
 PLATING ON TAILS: TIN OR TIN/COPPER
 ALLOY OVER SILVER

EXAMPLE:

PART NUMBER RJHSE-538X

LED COLOR CODE

CODE	LED 2 (LEFT)	LED 1 (RIGHT)	CODE	LED 2 (LEFT)	LED 1 (RIGHT)	CODE	LED 2 (LEFT)	LED 1 (RIGHT)
0	BLOCKED	BLOCKED	9	GREEN	BLOCKED	J	BiC RD/GR	YELLOW
1	YELLOW	GREEN	A	BiC GR/YE	BiC GR/YE	K	YELLOW	BiC GR/OR
2	BLOCKED	GREEN	B	BiC RD/GR	BiC RD/GR	L	BiC GR/YE	RED
3	YELLOW	BLOCKED	C	BiC RD/GR	BiC GR/YE	M	RED	YELLOW
4	GREEN	YELLOW	D	GREEN	BiC GR/YE	P	GREEN	BiC RD/GR
5	GREEN	GREEN	E	YELLOW	BiC GR/YE	R	BiC GR/OR	GREEN
6	YELLOW	YELLOW	F	BiC GR/YE	YELLOW	T	RED	RED
7	RED	GREEN	G	BiC GR/OR	BiC GR/OR	V	BiC RD/GR	GREEN
8	GREEN	RED	H	BiC GR/YE	GREEN	W	ADDITIONAL OPTIONS	

PRIMARY COLOR FOR BI-COLOR LEDS IN STANDARD ANODE/CATHODE CONFIGURATION IS:
 RED-GREEN= RED
 RED-YELLOW= RED
 GREEN-YELLOW= GREEN
 GREEN-ORANGE= GREEN

EXAMPLE OF ADDITIONAL LED OPTIONS:

PART NUMBER RJHSE-538W-01Y

ADDITIONAL LED COLOR CODE

↑ DENOTES ADDITIONAL LED OPTIONS TO BE USED

CODE	LED 2 (LEFT)	LED 1 (RIGHT)	CODE	LED 2 (LEFT)	LED 1 (RIGHT)	CODE	LED 2 (LEFT)	LED 1 (RIGHT)
0	DO NOT USE		5	BLOCKED	YELLOW	A	LOWC YE	LOWC YE
1	RED	BLOCKED	6	RED	BiC RD/GR	B	LOWC YE	LOWC GR
2	BiC GR/OR	YELLOW	7	BLOCKED	BiC RD/GR	C	LOWC GR	LOWC YE
3	YELLOW	RED	8	BiC RD/GR	BLOCKED	D	LOWC GR	LOWC GR
4	BLOCKED	RED	9	BiC GR/YE	BLOCKED	M	LOWC RD	LOWC YE

LEGEND

BiC=BI-COLOR LED
 LOWC=LOW CURRENT LED
 YE=YELLOW
 GR=GREEN
 RD=RED
 OR=ORANGE

NOTE:

THE TWO DIGITS PRECEDING THE ADDITIONAL LED CODE MUST BE USED IN THE PART NUMBER, WHEN ORDERING ANY OF THE ADDITIONAL LED OPTIONS.

THIS DOCUMENT CONTAINS PROPRIETARY INFORMATION AND SUCH INFORMATION MAY NOT BE DISCLOSED TO OTHERS FOR ANY PURPOSE OR USED FOR MANUFACTURING PURPOSES WITHOUT WRITTEN PERMISSION FROM AMPHENOL CANADA CORP.

DRAWN K. LAMBIE	DATE SEP21/04	Amphenol Canada Corp.	
DESIGNED			
CHECKED		TITLE LED OPTIONS FOR RJHSE, SINGLE OR MULTI-PORT CONNECTORS -RoHS COMPLIANT	
I. E. APPRD.			
Q. A. APPRD.		DWG DRAWING NO. P-RJHSE-LEDS	
DWG. APPRD.			
ENG. REL. NO.		REF. EAR 12481	REV. A
DIMENSIONS ARE IN INCHES [mm]	CODE ID. NO. 03554	SCALE	WT. -----
		SURF. -----	SHEET 1 OF 1